

**TRACTOR  
SHOP  
MANUAL**

**SUPPLEMENT**

● **POWER STEERING**

Prepared By

**TRACTOR AND IMPLEMENT DIVISION  
FORD MOTOR COMPANY**

# FOREWORD

This supplementary shop manual contains all of the information necessary for servicing power steering on Ford Series 700 and 900 Tractors.

The manual contains information on the construction, operation, overhaul, maintenance and trouble shooting of the power steering system. Wherever possible, the step-by-step service procedures are accompanied by disassembled views and servicing illustrations.

Keep this supplement with your copy of the Tractor Shop Manual, and in a location where it will be readily available for use at all times.

**TRACTOR AND IMPLEMENT DIVISION  
FORD MOTOR COMPANY  
SERVICE DEPARTMENT**

# TABLE OF CONTENTS

| Subject        | Page |
|----------------|------|
| Foreword ..... | 2    |

## STEERING SYSTEM

### CHAPTER I—POWER STEERING (TRICYCLE TRACTORS)

|   |    |
|---|----|
| Section 1. Construction and Operation .....                         | 4  |
| Pump Assembly .....   | 5  |
| Control Valve and Power Cylinder .....                              | 6  |
| Straight Ahead Driving .....  | 7  |
| Left Turn .....   | 9  |
| Right Turn .....  | 9  |
| Operation Without Pressure Supply .....                             | 9  |
| Section 2. Overhaul—Pump Assembly .....                             | 9  |
| Removal .....   | 9  |
| Disassembly .....   | 9  |
| Cleaning, Inspection and Repair .....                               | 10 |
| Assembly .....  | 12 |
| Installation .....  | 12 |
| Section 3. Overhaul—Control Valve and Power Cylinder Assembly ..... | 13 |
| Removal .....   | 13 |
| Control Valve Disassembly .....                                     | 13 |
| Control Valve Inspection .....                                      | 14 |
| Control Valve Assembly .....  | 15 |
| Power Cylinder Disassembly, Inspection and Repair .....             | 16 |
| Power Cylinder Assembly and Installation .....                      | 16 |
| Section 4. Maintenance .....  | 17 |
| Section 5. Trouble Shooting .....                                   | 18 |

# STEERING SYSTEM

## Chapter

I

# Power Steering (Tricycle Tractor)

| Section |  | Page |
|---------|--|------|
| 1       | Construction and Operation .....                         | 4    |
| 2       | Overhaul—Oil Pump Assembly .....                         | 9    |
| 3       | Overhaul—Control Valve and Power Cylinder Assembly ..... | 13   |
| 4       | Maintenance .....  | 17   |
| 5       | Trouble Shooting .....                                   | 18   |

The Ford Power Steering system is a linkage type system used on Series 700 and 900 Tractors. The system utilizes the conventional Ford Tractor steering gear and part of the linkage is replaced to provide a hydraulic power assist in all steering operations. In the event of power assist failure, the system provides a mechanical steering control which enables the tractor operator to exercise complete control of the steering system at all times.

A detailed description of each of the power steering units and its operation is given under the heading "1. Construction and Operation." The servicing procedures for the components are given under the headings "2. Overhaul—Pump Assembly" and "3. Overhaul—Control Valve and Power Cylinder Assembly." Information regarding maintenance and trouble shooting is presented under the headings "4. Maintenance" and "5. Trouble Shooting."

## I. CONSTRUCTION AND OPERATION

The Ford Power Steering system consists of a pump and reservoir assembly with an integral combined flow

control and relief valve; a double acting cylinder and control valve assembly; a two sheave pulley and the

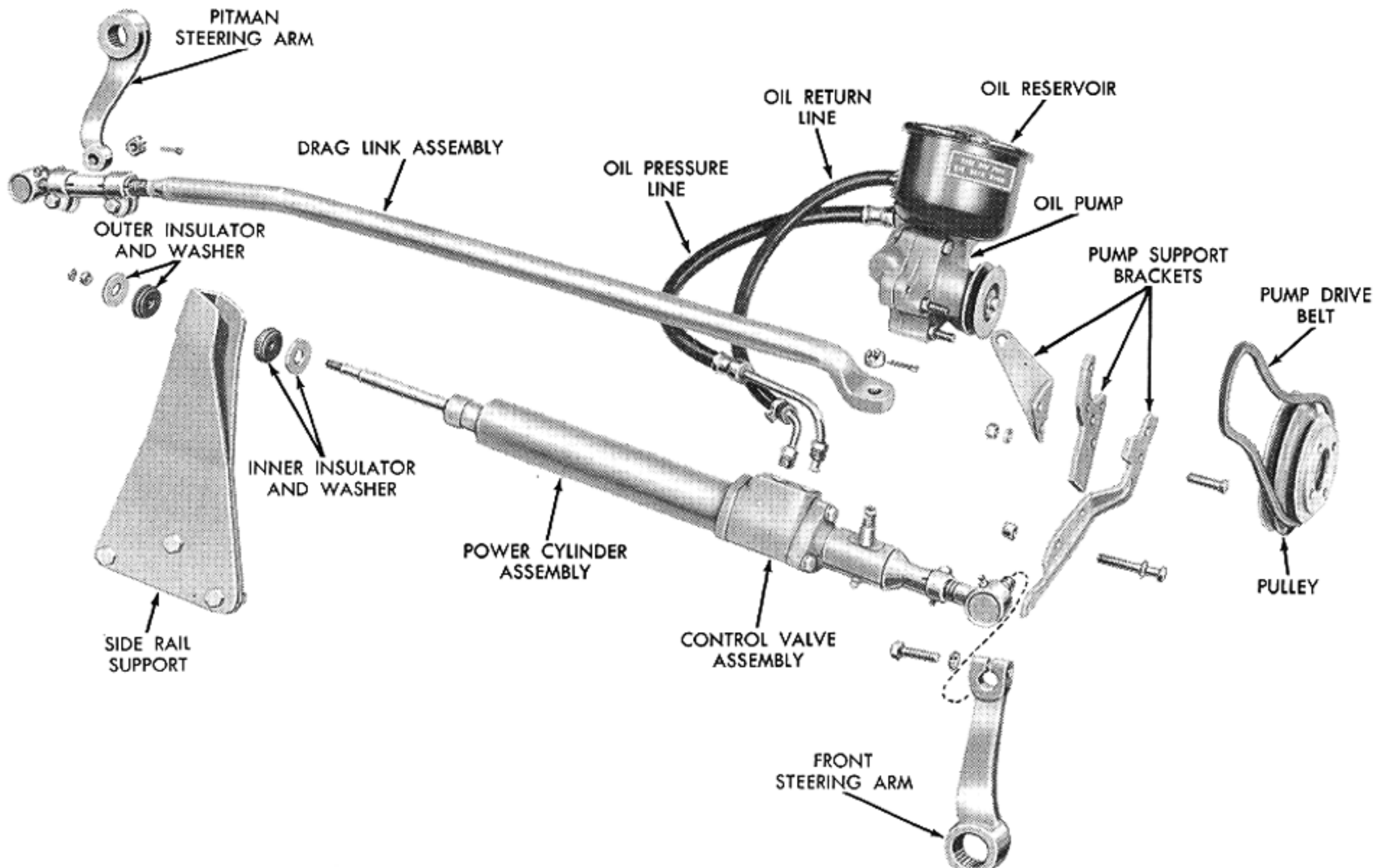

Figure 1—Power Steering System Components

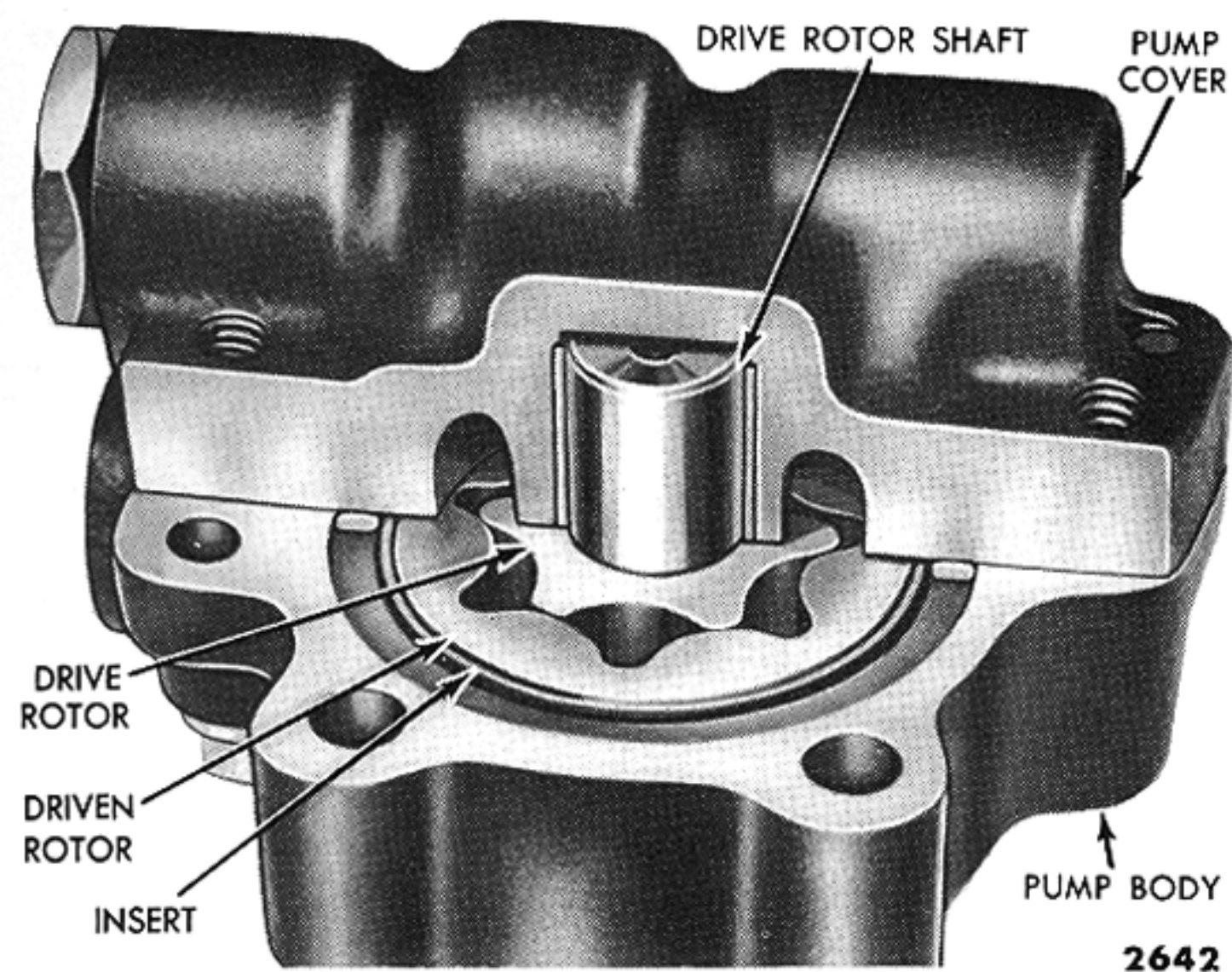

Figure 2—Cutaway View of Oil Pump

connecting hoses and linkage.

The construction and operation of the power steering unit is explained under headings which indicate the unit or condition involved.

## A. Pump Assembly

The pump used on the power steering system is driven by a single V-belt from the two sheave crankshaft pulley. The pump body is bolted to the pump support bracket. This support bracket is attached to the right front of the timing gear cover. Two elongated bolt holes in the pump adjusting bracket provide a means for adjusting the pump drive belt tension.

An oil reservoir is mounted on the pump body. The reservoir is held in place by the oil reservoir retaining bolt which threads into the pump body. A replaceable filter element is installed on a support plate which seats under the retaining bolt. A spring loaded hook, installed through the center hole of the element, holds the filter element in place on the support plate. Should the filter element become clogged, the spring seat acts as a relief valve, allowing the oil to by-pass the filter.

Correct oil level is maintained when the oil is within  $\frac{1}{2}$  inch of the top of the reservoir. A gasket is provided between the cover and reservoir body, and gaskets are installed between the oil reservoir and pump body. During operation, oil flows from the return line through the filter support, then through the filter element to the reservoir. The oil then enters the pump through a passage in the bottom of the reservoir.

A six-lobed drive rotor and seven-lobed driven rotor are installed in the cast iron pump body (see Figure 2).

The drive rotor is keyed to the pump drive shaft and

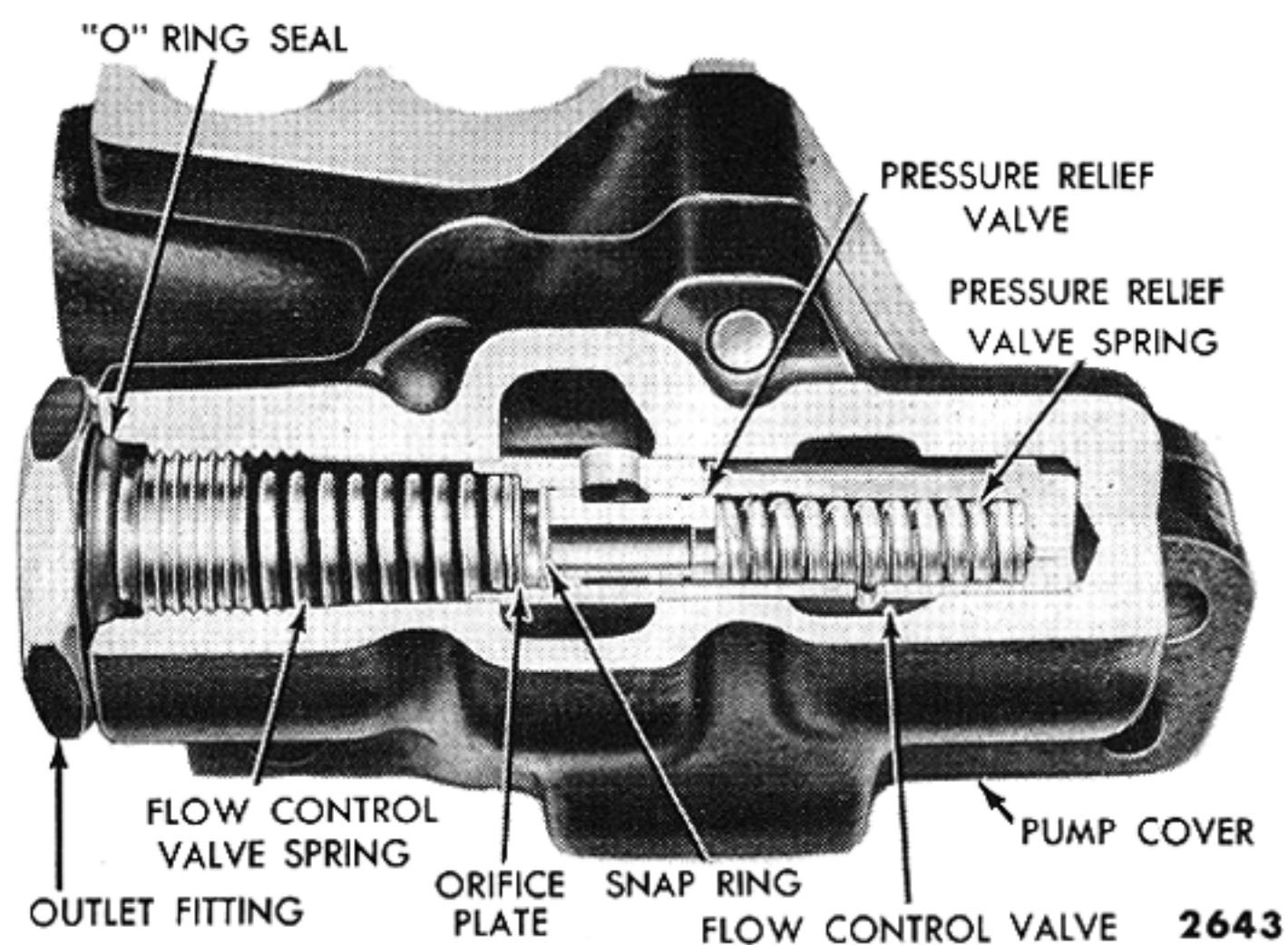

Figure 3—Cutaway View of Flow Control Valve

is meshed with the lobes of the driven rotor. The drive shaft is supported at the pulley end by a sealed ball bearing assembly which is a slip fit in the pump body and held in place by a snap ring. A lip-type spring loaded oil seal is installed behind the bearing. The center and inner end of the drive shaft are supported by bronze bushings and pressed into the pump body and pump cover.

As the pump rotors rotate, the pockets formed between the rotor lobes increase, then decrease in volume to propel oil from the suction (intake) side to the discharge side of the pump. The output of the pump must be high enough to provide the necessary power assist when the tractor is being turned with the engine idling. When the engine is at idle speed, the pump is operating at its minimum output which is great enough to provide the hydraulic assist for turning.

To limit pump output at higher engine speeds, a spool-type, spring loaded flow control valve is provided in a bore in the pump cover. See Figure 3.

The valve, which is hollow and closed at one end, has two small metering orifices drilled  $180^\circ$  apart through its walls. A cylindrical pressure relief valve is installed inside the flow control valve (Figure 3). This valve is also spring loaded. The pressure relief valve spring and valve are held in place by a snap ring, as shown. The flow control valve spring and valve are retained in the pump cover by an oil outlet fitting which is sealed with a neoprene "O" ring to prevent leakage. An orifice plate with a small metering hole in its center is installed between the flow control valve spring and the pressure relief valve snap ring.

The flow control valve limits the output of the pump to approximately 2.75 gallons per minute, regardless of pump speed. This is accomplished in the following

Oil from the pressure side of the pump flows into the chamber containing the flow control valve. A flat ground on the land at the closed end of the valve allows the oil to flow behind the closed end of the valve. The oil also flows to the inside of the valve through two metering holes in the wall of the valve. From here, the oil flows through the pressure relief valve and orifice plate and out through the pump discharge to the control valve.

When the pump speed is increased, due to an increase in engine speed, the pump output tends to exceed 2.75 gallons per minute. This creates a pressure differential between the outside and the inside of the flow control valve, due to the flow through the metering orifices. Since the pressure on the exterior of the closed end of the flow control valve exceeds the pressure on the spring loaded end, (due to a pressure drop after oil passes through the metering hole) the entire valve assembly moves to the left and compresses the flow control valve spring. This action uncovers an annular relief groove in the flow control valve body which permits excess oil to flow through a passage in the pump body and back to the intake side of the pump. Thus, the pump output is limited to 2.75 gallons per minute regardless of pump or engine speed.

The pump produces the oil pressure required in the system to meet all normal steering conditions. The amount of oil pressure produced depends on the pressure required to operate the power cylinder. The pressure relief valve installed in the flow control valve limits pump pressure to 1100 P.S.I. The pressure relief valve operates as follows:

The relief valve spring is designed so that a pressure of 1100 P.S.I. is required in the system to overcome the force of the spring. Since the area of the left face of the pressure relief valve is greater than the area of the right face, the valve will move to the right when the 1100 P.S.I. pressure is reached. This movement uncovers ports in the flow control valve which permits the oil to return to the intake side of the pump and prevents further pressure build-up. The relief valve action takes place regardless of the position of the flow control valve in its bore, since the action of the flow control valve controls only the volume of oil exhausted from the pump. For example, with the engine idling, the flow control valve does not open to pump suction as the output of the pump is below the 2.75 gallons per minute controlled output. If the wheels are turned against the stops with the tractor stationary, the pump builds up high pressure but the volume of oil exhausted still does not exceed 2.75 gallons per minute. Under this condition, the flow control valve remains closed, but the pressure relief valve opens the passage to the intake side of the pump

regulating the maximum pressure in the system to 1100 P.S.I.

## B. Control Valve and Power Cylinder

The front end of the control valve and cylinder assembly (see Figure 1) is threaded onto the drag link end which is attached to the steering spindle arm. The rear portion of the assembly is a tubular, double-walled cylinder containing a piston and rod assembly. The rear end of the piston rod is attached to the pedestal side rail support. Two rubber insulators and two washers are used to insulate the piston rod from the support. A lip type oil seal, bushing, dust seal and scraper are installed in the rod end of the cylinder, and are held in place by a snap ring. The front end of the power cylinder is mounted on the control valve housing and is held in place by three capscrews.

Two drilled oil passages interconnect the power cylinder and the control valve assembly. Oil flows through one passage between the cylinder walls to the piston rod end of the cylinder. The other passage carries oil directly into the piston end of the cylinder. Both passages are used as oil return lines.

Oil enters the power cylinder either ahead of the piston or behind the piston, depending on the turn being made. When the oil pressure in one end of the power cylinder becomes great enough, the cylinder moves on the piston rod to provide the power assist. As the cylinder moves, the oil in the opposite end of the cylinder is forced out and returns to the reservoir through the control valve.

The control valve assembly consists of the sleeve and flange assembly, the control valve housing and the internal parts (see Figure 13). The sleeve and flange assembly is bolted to the control valve housing.

The steering arm ball stud, ball stud seats, seat spring, ball stud retainer and spring stop plug are installed in the sleeve and flange assembly. The parts are held in place with a control valve spool stop screw which threads into the rear end of the ball stud retainer.

The spool type control valve is mounted on a bolt which passes through the control valve spool stop screw. A stop pin, installed through the stop screw and the head of the bolt, prevents rotation of the bolt. The valve spool and other parts are held in place by a self-locking nut. A lip type seal and a retainer are installed in the bore of the control valve housing at each end of the spool.

The control valve spool is constructed with three radial lands and four radial valleys to provide the passages necessary for the directional control of the fluid.

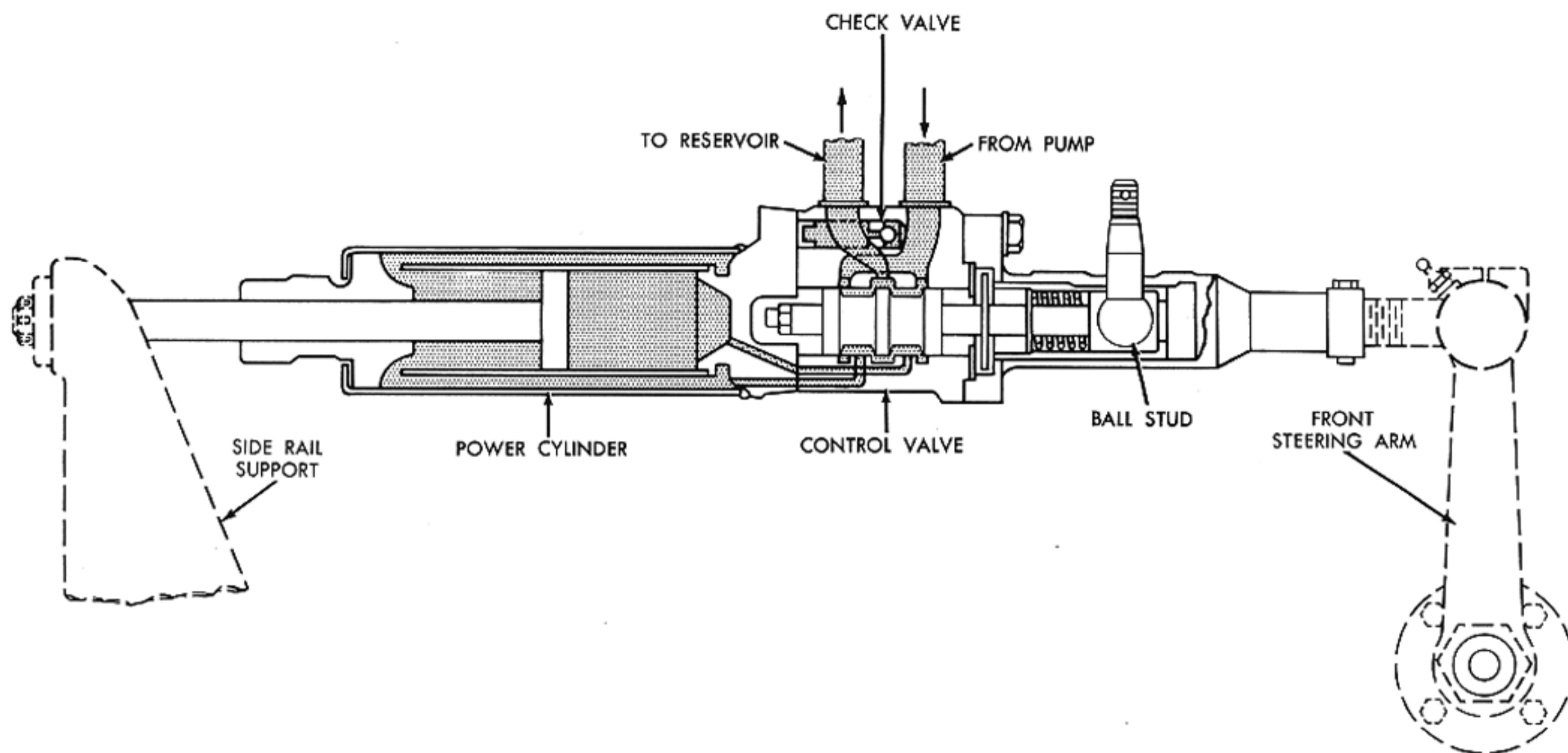

Figure 4—Oil Flow Diagram—Straight Ahead Driving

A ball type check valve assembly is threaded into the valve housing port through which fluid is returned to the reservoir. In addition to the reservoir port, the control valve housing has one port which admits fluid from the pump and two ports which are connected to the power cylinder through drilled passages.

In operation, oil pressure is delivered from the pump to the control valve through a flexible hose. When the steering wheel is turned, the steering drag link first moves the control valve spool within the control valve body. This action opens a series of ports in the valve body (see Figures 5 and 6) which regulates the oil flow to the power cylinder. The movement of the valve spool within the body is controlled, by positive stops, to approximately 0.060 inch. The parts are designed so that the power assist is accomplished before the valve spool reaches the stop, thus insuring sensitive response. As the steering drag link moves further, the entire control valve assembly and the steering spindle arm move as a unit, assisted by the power cylinder.

When the operator stops the steering wheel at the desired position, removing the thrust against the control valve, the movement of the steering arm by the cylinder will move the valve housing until the spool is in the center position. The valve spool also depends on hydraulic pressure for its centering force. This is

accomplished by means of oil passages between the two valleys in the valve spool and chambers between the outer lands and housing seals. Oil pressure in these chambers tends to move the spool away from the seals. If the spool is moved forward, the pressure in the chamber at the forward end increases in proportion to the pressure applied to the power cylinder. Thus, the hydraulic centering force provides a feel at the steering wheel which is proportional to the effort required to turn the front wheels.

### C. Straight Ahead Driving

When the tractor wheels are in the straight ahead position, the control valve spool is held in the center or neutral position (see Figure 4). In this position, oil from the pump flows by the valve spool land and returns to the reservoir through the port in the control valve housing.

Since only a small amount of back pressure exists in the system under this condition, the pump delivers just enough oil pressure to overcome the back pressure. The pump pressure is transmitted to both sides of the power cylinder piston, through the flexible lines, and a balanced condition exists.

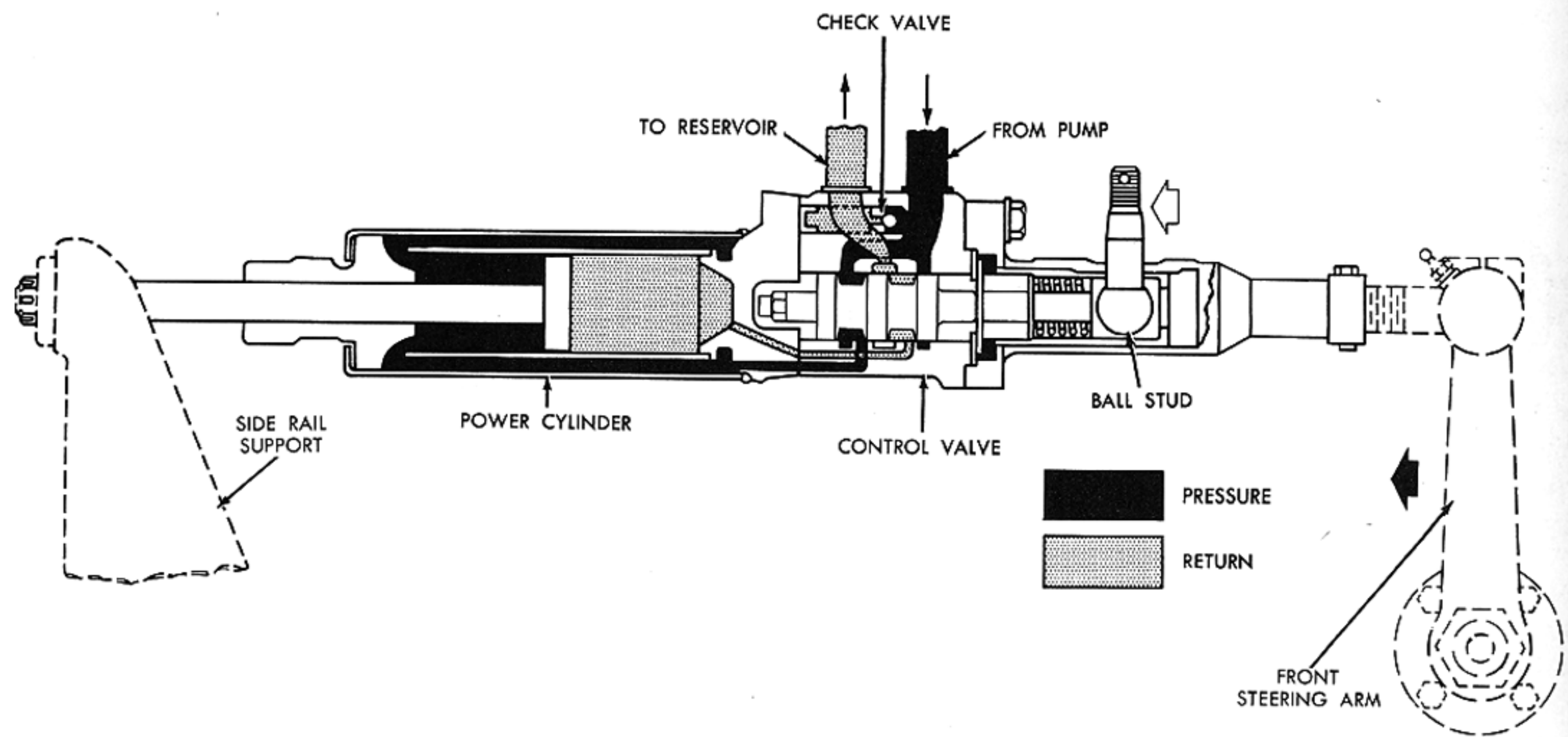

Figure 5—Oil Flow Diagram—Left Turn

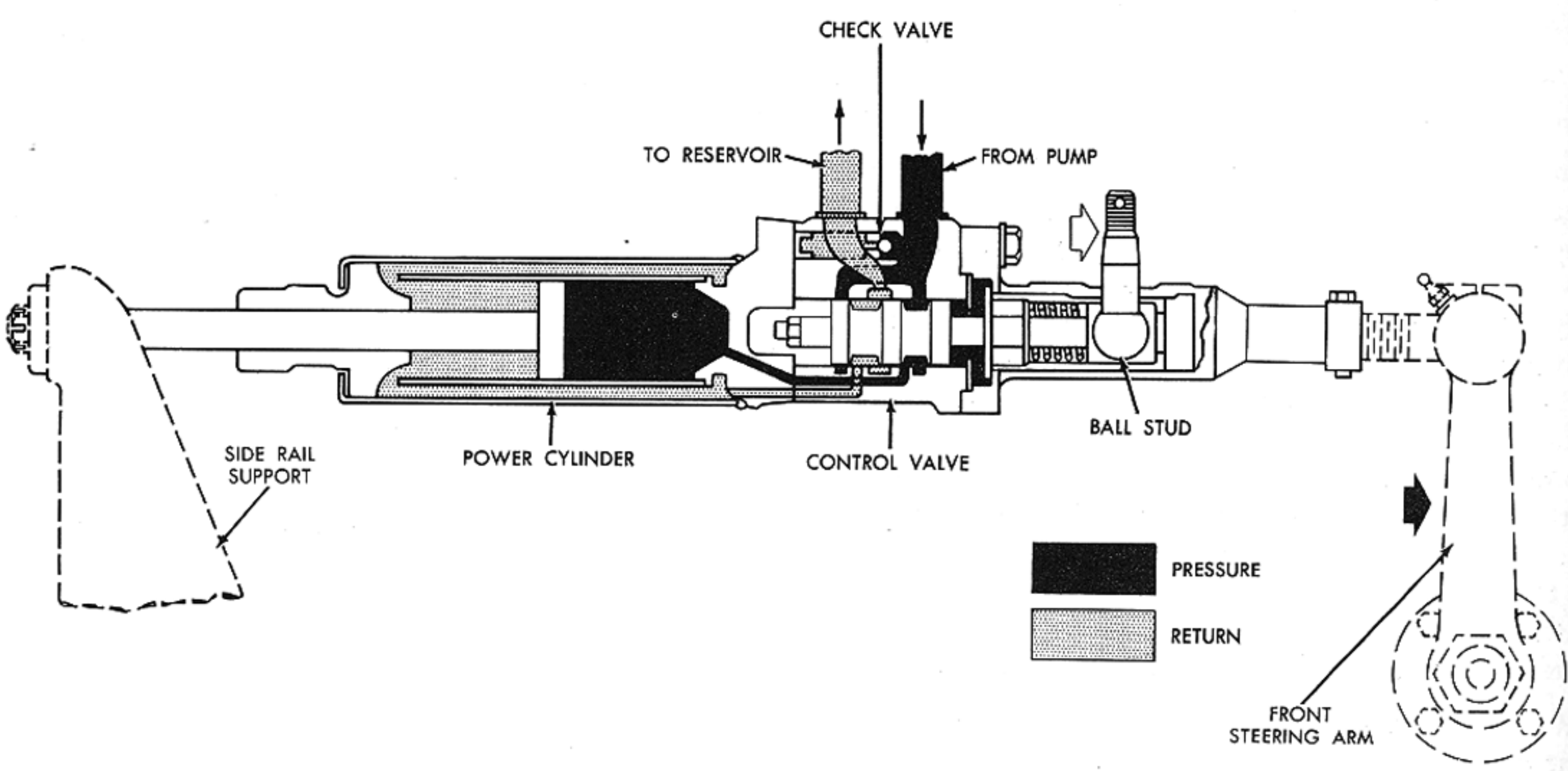

Figure 6—Oil Flow Diagram—Right Turn



## D. Left Turn

When the steering wheel is first turned to the left, the steering drag link exerts a force on the control valve spool which tends to move the spool to the rear (see Figure 5). When the spool is in this position, the oil passage leading to the front (piston) end of the power cylinder is closed to pump pressure, but is open to the reservoir. The passage leading to the rear (piston rod) end of the cylinder is open to pump pressure. As the oil from the pump flows into the power cylinder, the pressure increases until it is sufficient to force the cylinder and the steering spindle arm to the rear, thus providing the power assist for the left turn. The oil displaced from the front end of the power cylinder flows back through the control valve to the oil reservoir. When the steering wheel is stopped in the position which gives the desired turn, or the force on the wheel is reduced below the control valve centering force, the control valve spool returns to the center position, thereby stopping the power assist.

## E. Right Turn

When making a right turn, the steering drag link moves the control valve spool forward. The movement of the valve spool opens the oil pressure supply passage

in the valve housing which leads to the front (piston) end of the power cylinder (see Figure 6). As the pressure in the power cylinder increases, the cylinder and the steering spindle arm move forward, thus providing the power assist for the right turn. The oil displaced from the rear (piston rod) end of the power cylinder flows back through the control valve to the oil reservoir.

## F. Operation Without Pressure Supply

If the pump fails to deliver oil pressure for any reason, the tractor may be steered manually. Under this condition, the power steering system operates in the following manner:

When the steering wheel is turned, the movement of the steering drag link transmits the manually applied force to the control valve spool. The spool moves approximately 0.060 inch before it contacts its stop, then the full manual effort is transmitted mechanically to the steering linkage. With the valve spool off the center position, oil is directed to either end of the power cylinder through the check valve. Thus, manual movement of the power cylinder is not restricted by the necessity of forcing oil back through the pump, and steering effort is not appreciably increased over that required for the manual steering system.

## 2. OVERHAUL—PUMP ASSEMBLY

The procedures necessary for the overhaul of all pump assembly components are provided in this section under the headings, "A. Removal," "B. Disassembly," "C. Cleaning, Inspection and Repair," "D. Assembly," and "E. Installation." Specifications given throughout the section should be closely adhered to wherever they apply.

### A. Removal

1. Remove the oil reservoir cover, then withdraw as much oil as possible from the reservoir with a suction gun.
2. Disconnect the oil pump to control valve hose assemblies at the pump pressure and return line fittings. Fasten the ends of the hoses in a raised position to prevent oil drainage.
3. Loosen the pump drive belt adjusting bolts, then remove the pump belt. Remove the nuts and lockwashers from the belt adjusting bolts, remove the bolts and washers, then remove the pump and adjusting bracket as an assembly.

### B. Disassembly

1. Clean the outside of the pump and reservoir. Do not allow dirt to enter the pressure or return fitting holes.
2. Clamp the oil pump adjusting bracket in a vise. Lift the filter element retaining spring, hook spring seat and filter element from the reservoir.
3. Remove the oil reservoir retaining bolt, then remove the filter element support plate, reinforcement plate and reservoir from the oil pump housing. Remove the pump intake and reservoir retaining bolt gaskets from their location in the pump housing.
4. Remove the pump pulley screw, lockwasher and the flat washer, then remove the pulley and pulley key from the pump rotor shaft.
5. Remove the two capscrews and lockwashers which secure the pump cover to the pump body.
6. Remove the three adjusting bracket to pump body nuts and lockwashers, then remove the bracket from the body and from the vise.

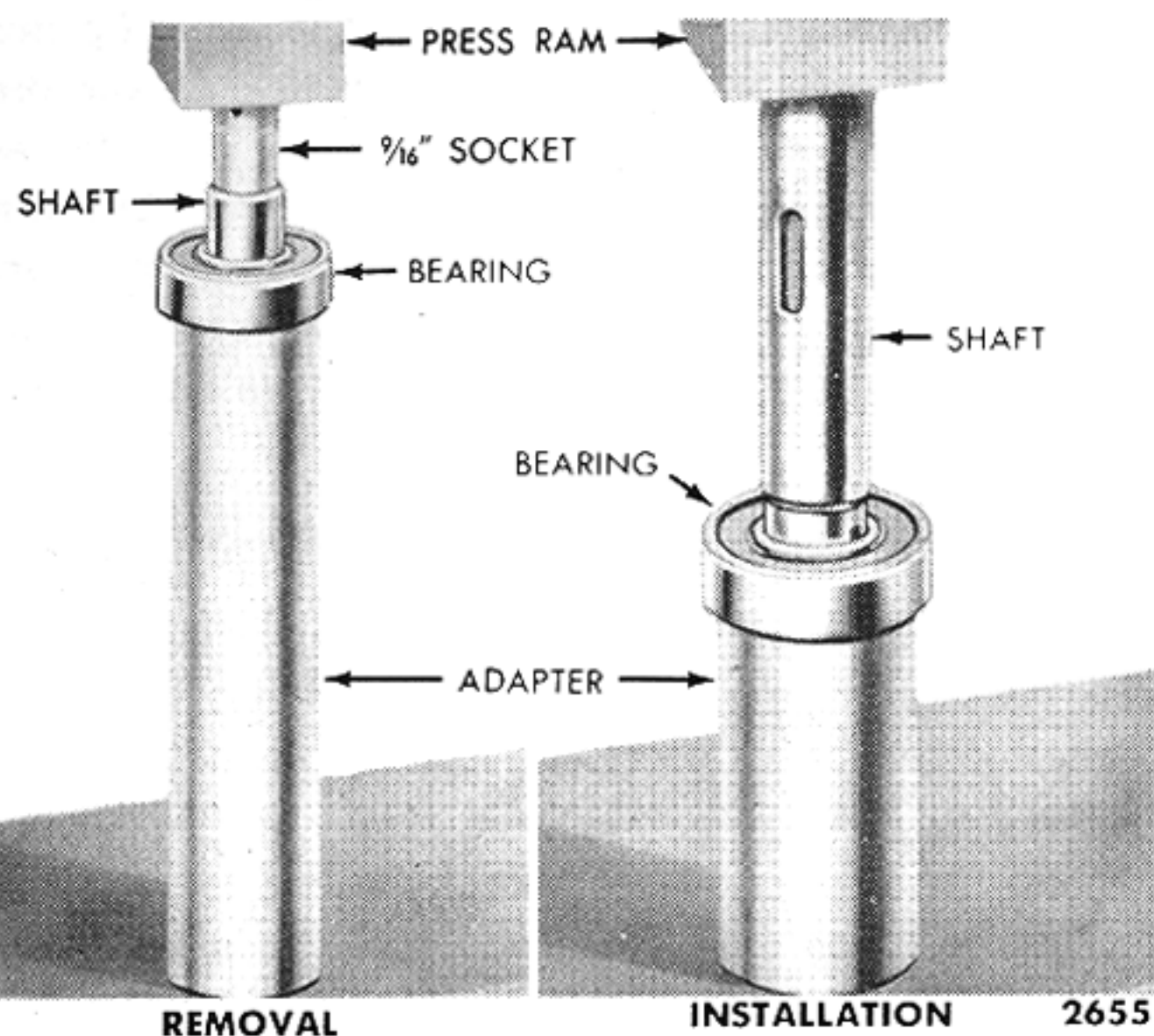

Figure 7—Rotor Shaft and Bearing Replacement

7. Remove the three mounting stud bolts that hold the pump cover to pump body, then separate the pump cover and pump housing. Tap the parts gently with a soft hammer if necessary.
8. Lift the pump cover gasket out of the groove in the pump housing.
9. Remove the oil pump rotors and the rotor drive key from the drive shaft.

**CAUTION:** Handle the rotors, pump body and cover carefully as nicks, burrs, cracks, or scratches may render them unfit for further service.

10. Clamp the pump body in a vise with soft jaws, then remove the rotor shaft bearing retainer with a screw driver.
11. Press or tap the rotor shaft and bearing from the oil pump housing, being careful not to damage the shaft or bearing. Inspect the rotor shaft bearing for smooth operation or for wear and other damage. If replacement is necessary, press the bearing off the shaft using an arbor press and an adapter which will bear against the bearing inner race. See Figure 7.
12. Inspect the rotor shaft oil seal for wear or damage. If the seal is worn or damaged, remove it from the pump body with a punch.
13. Lift the flow director "O" ring out of the bore in the pump housing.
14. Clamp the pump cover in a vise equipped with brass jaws, then thread the oil pump outlet fitting out of the pump cover. Slide the "O" ring off the fitting. Remove the flow control valve spring and the orifice plate from the pump cover.
15. Carefully pull the flow control valve out of the

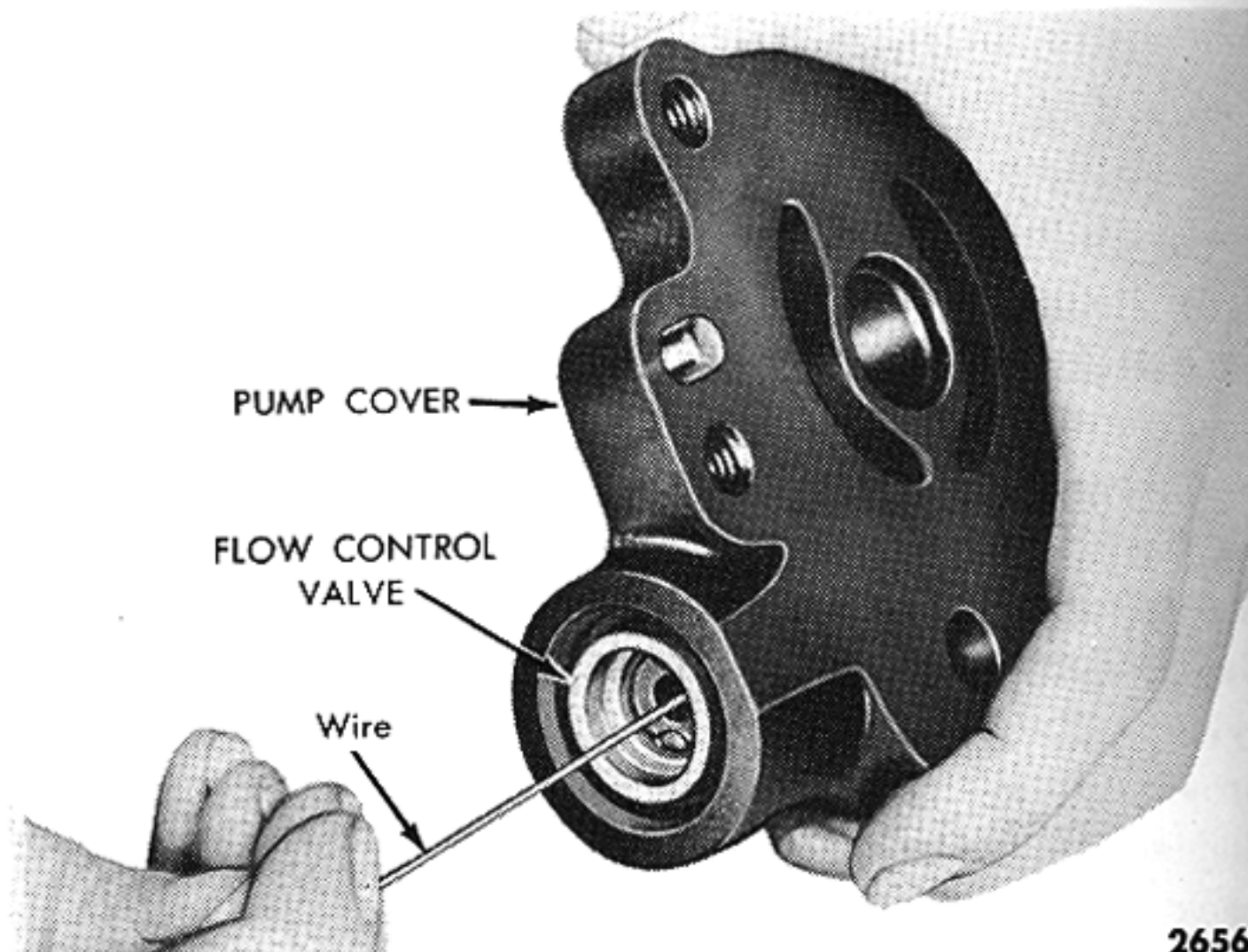

Figure 8—Flow Control Valve Removal

- pump cover with a wire, as shown in Figure 8.
16. Remove the retainer (snap ring) that secures the pressure relief valve and spring in the flow control valve. Remove the relief valve and spring from the bore of the flow control valve.

**CAUTION:** Handle the valves carefully to avoid damage.

### C. Cleaning, Inspection and Repair

Wash all parts, except the rotor shaft bearing assembly, in a suitable solvent.

Do not soak the bearing in solvent as the lubricant, sealed in the bearing, may become diluted by the solvent. Inspect the oil pump body and cover for signs of wear caused by the rotation of the rotors, then check the bushings in the body and cover for wear or scores. If the pump body or the bushing is worn or damaged, replace the pump body and rotor sub-assembly. If the pump cover or the bushing in the cover is worn or damaged, replace the cover and bushing assembly.

Inspect the drive and driven rotors for wear, cracks or scores. If either rotor is damaged or worn, replace the pump body and rotor assembly. If the rotors appear to be in good condition, proceed as follows:

1. Press the rotor shaft bearing onto the rotor shaft, as shown in Figure 7, until the bearing is seated against the shoulder on the shaft. Tap the shaft and bearing assembly into the pump body until the bearing is seated in the body.

**NOTE:** Apply pressure to the outer race of the bearing when installing in the pump body.

2. Install the drive rotor and pin on the rotor shaft, then install the driven rotor. Check the clearance

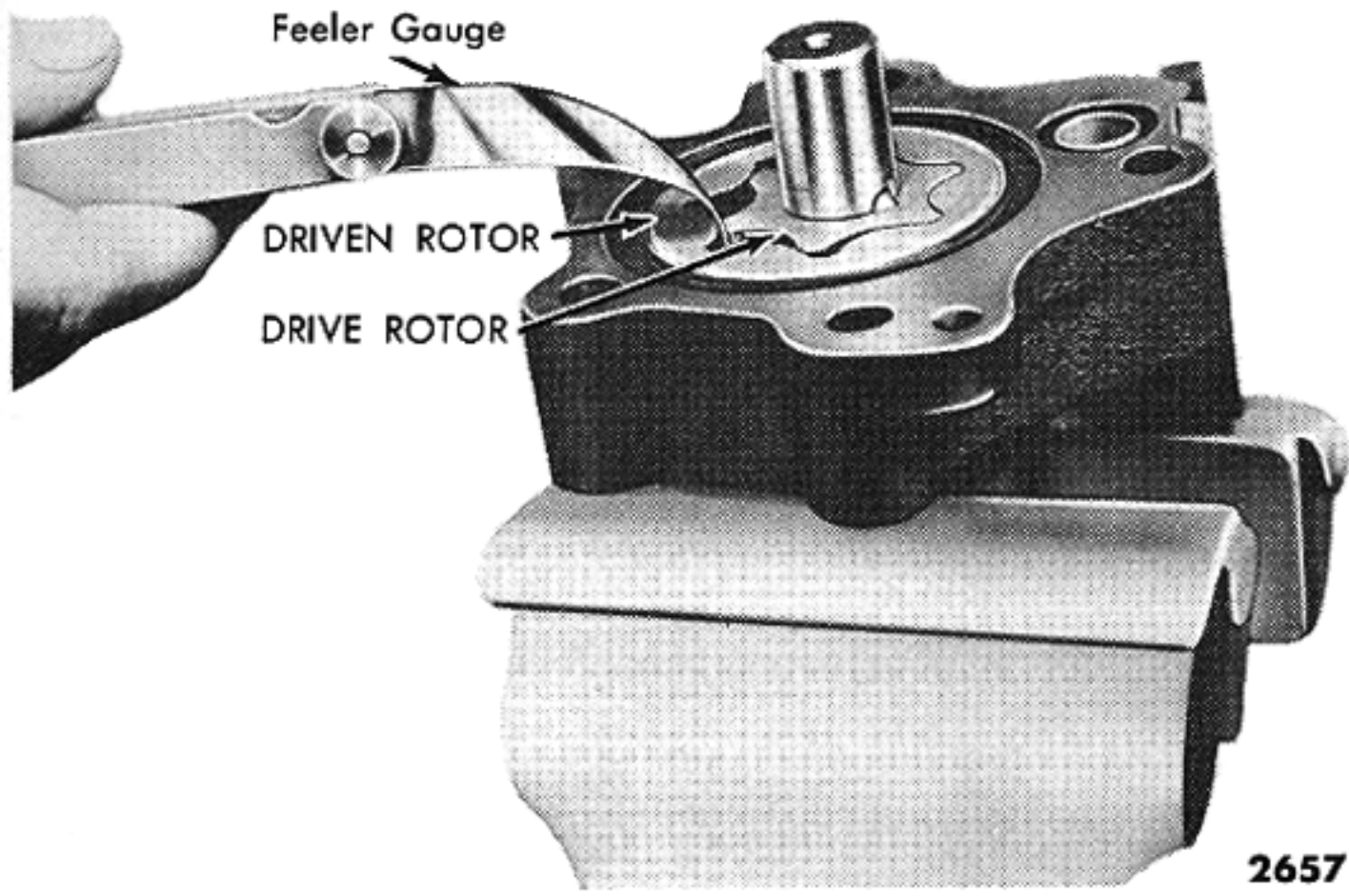

Figure 9—Checking Clearance Between Rotors

between the rotors, at all points, with a feeler gauge as shown in Figure 9. If the clearance exceeds 0.006 inch, replace the pump body and rotor assembly.

3. Check the clearance between the top of the rotors and the surface of the pump body with a feeler gauge and a straight edge as shown in Figure 10. If the clearance exceeds 0.0025 inch, replace the pump body and rotor assembly.
4. Check the clearance between the driven rotor and the insert in the pump body as shown in Figure 11. If the clearance exceeds 0.006 inch, replace the pump body and rotor assembly. If all the clearances are within specifications, remove the rotors, shaft, and bearing from the pump body.
5. Dry the pressure relief valve and the bore of the flow control valve thoroughly. Insert the relief valve in the bore of the flow control valve, then shake the valve. If the relief valve does not move freely in the bore, remove it and check for burrs. Remove all

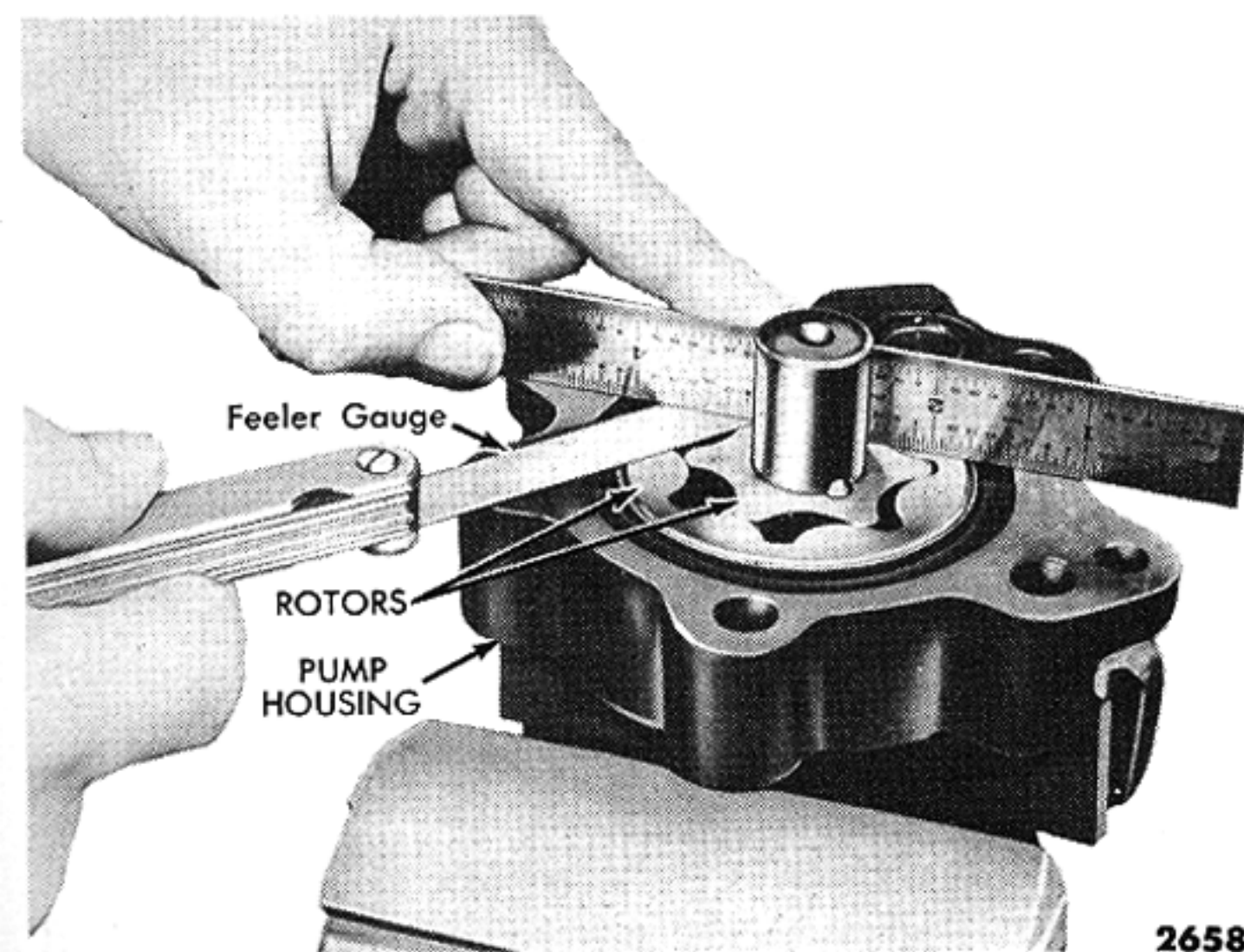

Figure 10—Checking Rotor to Pump Body Clearance

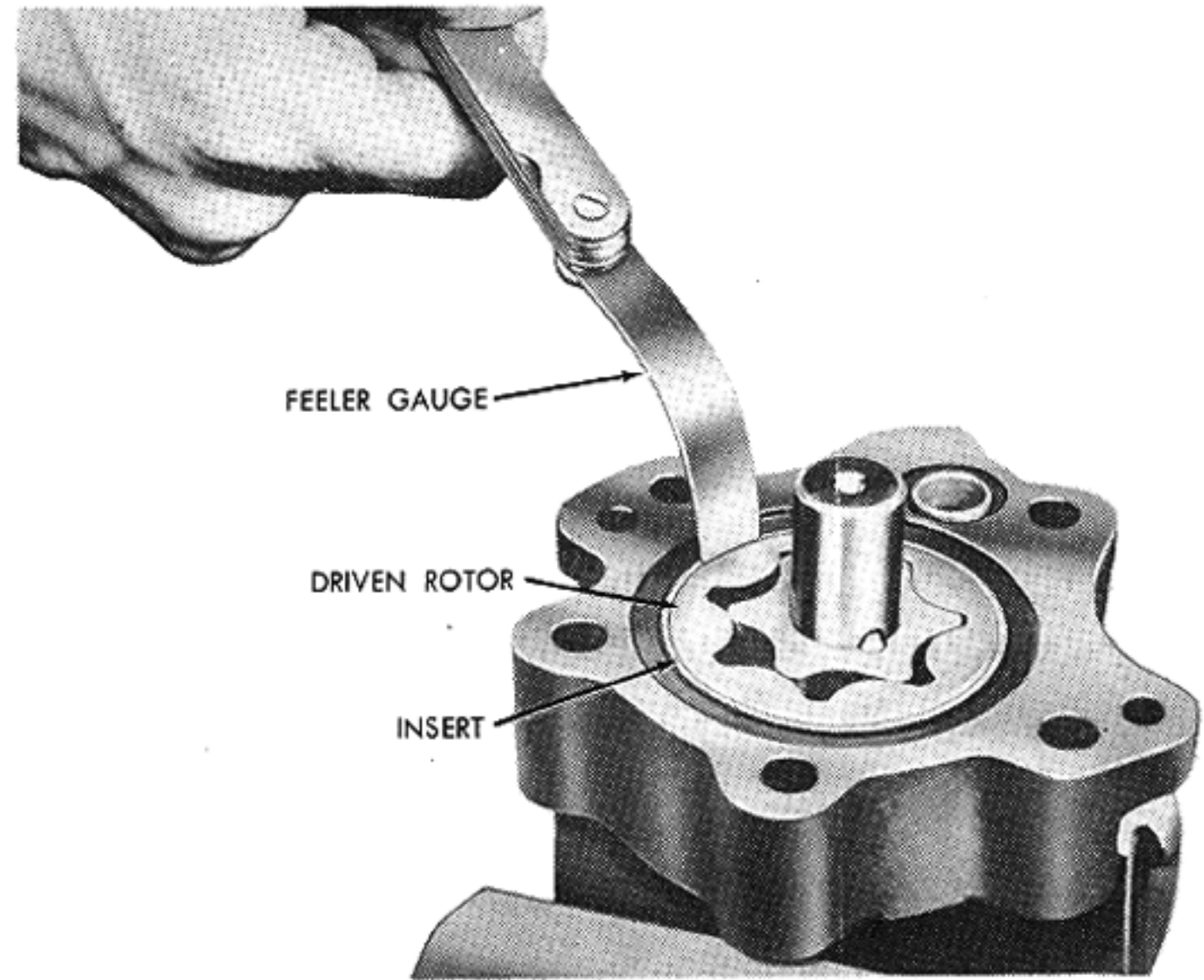

Figure 11—Checking Rotor to Insert Clearance

burrs with crocus cloth. Check the flow control valve for free movement in the bore of the pump cover. If necessary, remove all burrs with crocus cloth.

6. Check the tension of the flow control valve spring with an engine valve spring checking tool. The

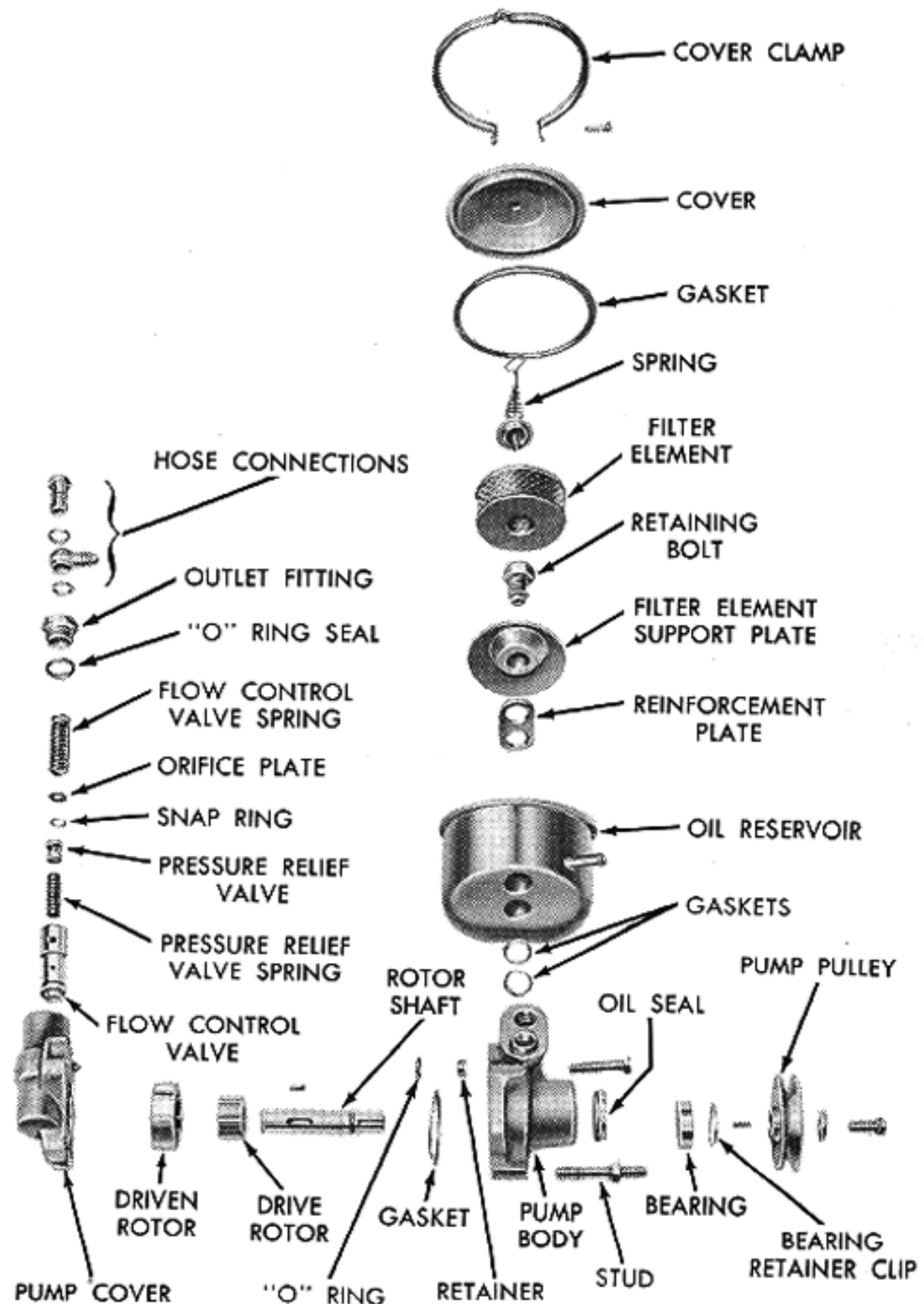

Figure 12—Oil Pump in Assembly Sequence

spring should exert a pressure of 16 pounds, plus or minus 1½ pounds, when compressed to a height of 1<sup>13</sup>/<sub>64</sub> inches. If the spring tension is not within specifications, replace the spring.

7. Check the tension of the pressure relief valve spring. The spring should exert a pressure of 22 pounds plus or minus 1 pound when compressed to a height of 1<sup>3</sup>/<sub>16</sub> inches. If the spring tension is not within specifications, replace the spring.

## D. Assembly

1. Coat all parts with Automatic Transmission Fluid—Type A, prior to assembly.
2. If the rotor shaft oil seal was removed, install a new seal as follows:  
Coat the lip of the new seal with Lubriplate, or an equivalent lubricant. Position the seal in the bore of the pump body with the lip of the seal toward the pump rotors. Drive the seal into the pump body until firmly seated, using a suitable socket that will bear on the outer diameter of the seal.
3. Tap the rotor shaft and bearing assembly into the pump body until the bearing is seated in the body. Install the bearing retainer.
4. Install the drive rotor and pin on the rotor shaft, then install the driven rotor.
5. Position the pressure relief valve spring and the pressure relief valve in the bore of the flow control valve. Install the valve retainer.
6. Place the flow control valve in the bore of the pump cover, being careful not to damage the valve lands or the bore of the cover. Place the orifice plate and the flow control valve spring on the valve.
7. Install a new "O" ring seal on the oil pump outlet fitting, then thread the fitting into the pump cover. Tighten the fitting to 40-45 ft. lbs. torque.
8. Position a new oil pump cover gasket in the groove in the pump body. Install a new "O" ring seal around the flow director in the pump body.
9. Position the pump cover on the pump body, then install the two body to cover attaching lockwashers and capscrews in the holes closest to the reservoir mounting pad. Install the three pump adjusting bracket to pump body studs and lockwashers. Tighten the two capscrews and three studs evenly to 20-30 ft. lbs. torque.

**IMPORTANT:** *Check the rotor shaft for free operation. The shaft must rotate freely without binding. If the shaft does not rotate freely, disassemble the pump and determine the cause.*

10. Install the three spacers and the pump adjusting bracket on the studs, then secure the bracket to the pump, using three lockwashers and nuts.
11. Install the pump pulley key in the keyway in the rotor shaft, then tap the pump pulley on the shaft.
12. Install the flat washer and the screw and lockwasher which secure the pulley to the shaft. Tighten the screw to 18-20 ft. lbs. torque.
13. Place the pump adjusting bracket in a vise, then position new gaskets on the top of the pump body.
14. Place the oil reservoir on the pump body, then position the reinforcement plate in the reservoir with the two raised lugs up, at the pump intake port location.
15. Install the filter element support plate and reservoir retaining bolt, then tighten securely. Position the filter element on the support plate. Lay the filter element retaining spring seat on the element, then place the retaining spring in position on the spring seat.
16. Install a new reservoir cover gasket in the reservoir cover, then position the cover on the reservoir body. Install the cover to reservoir clamp, but do not tighten securely at this time.

## E. Installation

1. Position the pump and pump adjusting bracket in the pump support and pump mounting brackets. Install the pump adjusting bolts through the support plate, mounting bracket and adjusting bracket, then install flatwashers, lockwashers and nuts on the bolts. Tighten the adjusting bracket to pump support bolt nuts finger tight.
2. Position the oil pump belt on the crankshaft pulley and oil pump pulley. Raise the pump assembly to tighten the belt, then check the belt tension. The belt should have ¼ inch deflection, at the center of the belt, under 5-7 lbs. thumb force. When the correct belt tension is obtained, tighten the adjusting bracket to pump support bolts to 20-30 ft. lbs. torque.
3. Install the pump return hose to the pump reservoir and install the hose clamp on the hose at the reservoir connection as shown in Figure 14.
4. Install the pump pressure hose to the pump pressure port as shown in Figure 14 and tighten the fitting to approximately 30-35 ft. lbs. torque.

**CAUTION:** *Do not reverse the inlet and outlet hoses. If reversed, the power steering system will not operate properly.*

5. Prior to filling the pump reservoir, turn the tractor wheels to the left against the stops so that the piston will be retracted in the cylinder. Remove the reservoir cover clamp and cover and fill the reservoir to within  $\frac{1}{2}$ " of the top with Automatic Transmission Fluid-Type A. Replace the cover and bleed the system as follows:
  - a. Start the tractor engine but do not accelerate.
  - b. Operate the power steering system by slowly turning the steering wheel from one extreme position to the opposite extreme position. *Do not hold against stops.*
  - c. Repeat the steering cycle until system is free of air. This can be noted by observing the oil in the reservoir for turbulence or boiling action of the oil during steering action.
  - d. Operate the system until turbulence ceases.
  - e. Check the hose connections for any oil leakage or intake of air.
  - f. Turn the front tractor wheels to the left and stop the engine. Refill the reservoir to within  $\frac{1}{2}$ " of the top. Replace the reservoir cover and clamp.

### 3. OVERHAUL—CONTROL VALVE AND POWER CYLINDER ASSEMBLY

#### A. Removal

If it is determined that the control valve and power cylinder assembly is not operating properly, the assembly must be removed from the tractor and completely disassembled to perform the necessary repairs.

1. Disconnect the control valve to pump hoses at the control valve. Raise both hoses above the pump reservoir and secure in this position to prevent oil drainage from the reservoir.
2. Turn the front wheels to the full right position and full left position several times to force all the oil from the control valve and power cylinder assembly.
3. Loosen the control valve sleeve clamp bolt nut.
4. Remove the cotter pin and castellated nut which secures the front end of the drag link to the steering ball stud. Use special tool, Part No. OTC 1002 Gear Puller, to remove the drag link from the steering ball stud.

**NOTE:** *Position a hex nut over the point end of the gear puller to protect the steering ball stud during this operation. The ball stud is not provided with a point locating hole. Do not remove the drag link from the steering ball stud in any manner other than specified. The use of pinch bars or similar leverage tools applied to the sleeve assembly, or valve housing as a fulcrum for drag link removal, may cause extensive internal damage to these assemblies.*

5. Remove the piston rod locking nut, jam nut, outer washer and outer rubber insulator from the piston rod, then remove the rod from the side rail rod support.
6. Remove the locking bolt and washer from the front steering arm, then remove the cylinder and valve assembly by tapping the front ball stud out of the steering arm.

7. Removal of the drag link from the Pitman steering arm is not necessary.

#### B. Control Valve Disassembly

1. Place the control valve and cylinder assembly in a vise equipped with soft jaws. Completely loosen the three control valve sleeve to control valve housing to power cylinder retaining bolts.
2. Remove the power cylinder from the valve housing.
3. Remove the lock nut from the end of the control valve spool bolt.
4. Remove the control valve sleeve and flange assembly from the control valve sleeve housing.
5. Remove the retainer and seal from the control valve spool at the cylinder end of housing.
6. Remove the control valve spool from the cylinder end of the valve housing.
7. Remove the retainer and seal from the sleeve end of the control valve housing.
8. Remove the sealing plug from the power cylinder end of the valve body by inserting the short turned end of a  $\frac{3}{32}$ " Allen wrench into the oil return hole and force the plug out of the cylinder end of the valve housing.
9. Remove the check valve assembly with a screw driver.
10. Place the control valve sleeve and flange assembly in a vise and remove the dust shield from the control valve sleeve. Pull the valve spool bolt, stop screw and ball stud retainer outward until the ball stud is against the end of the elongated slot of the sleeve then remove the stop pin out of the valve stop screw.
11. Turn the control valve spool stop screw in a counter-clockwise direction to remove the screw from the ball stud retainer. Remove the valve spool bolt from

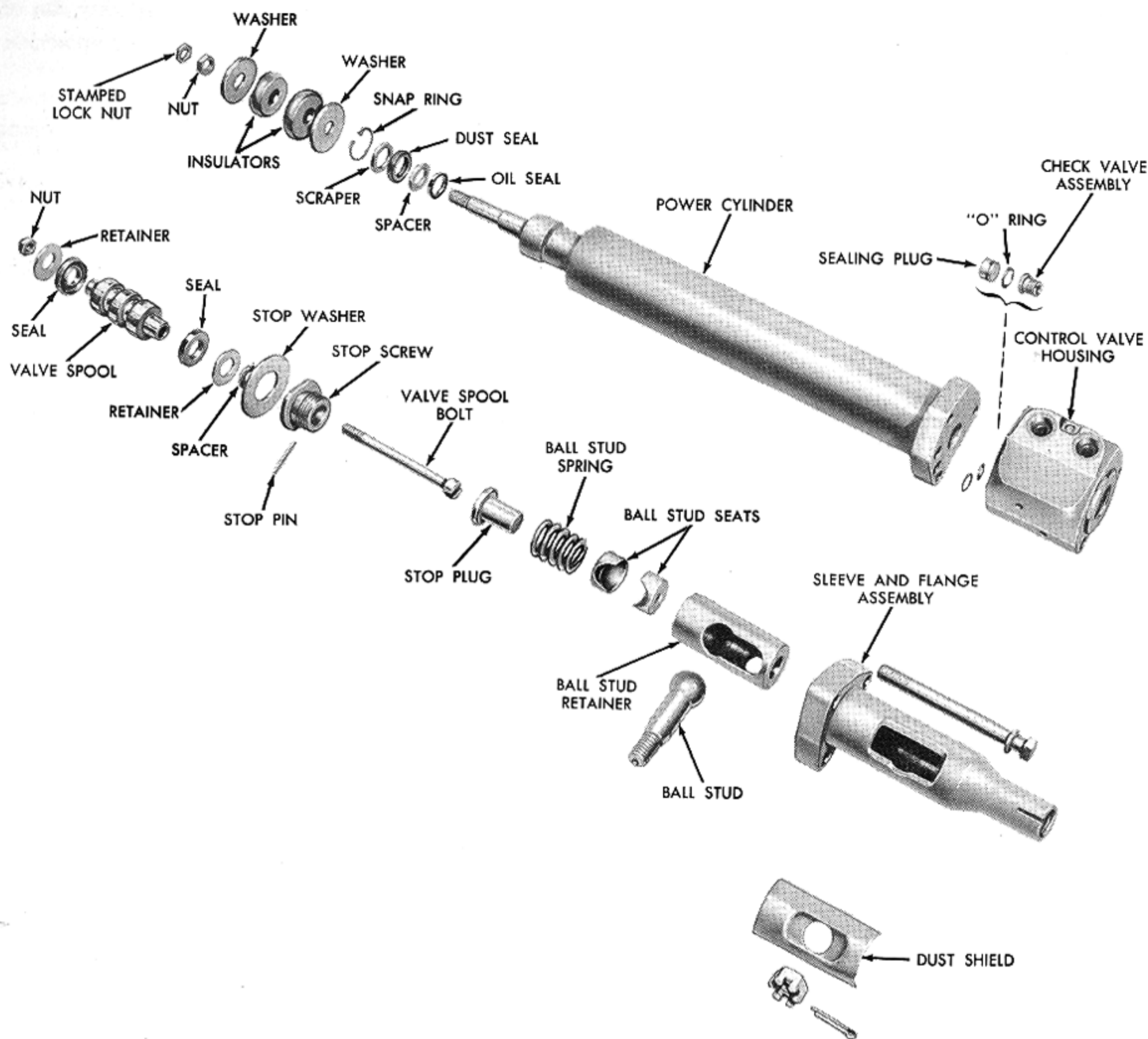

Figure 13—Control Valve and Power Cylinder in Assembly Sequence

the valve spool stop screw.

12. Remove the stop plug, ball socket spring and one ball stud seat from the ball stud retainer.
13. Slide the ball stud and retainer toward the closed end of the sleeve, then remove the ball stud from the sleeve by dropping it into the retainer and out the open end.
14. Remove the retainer and the remaining ball stud seat from the sleeve and flange assembly.

### C. Control Valve Inspection

1. Clean all the parts of the control valve assembly thoroughly and inspect them for wear or damage. Replace any parts if necessary.

2. Inspect the control valve seals and retainers for wear or damage. Examine the lips of the seals carefully for nicks or scratches that could allow fluid to escape from the valve. Examine the retainers for nicks or scores. Replace the seals and retainers if necessary.
3. Inspect the control valve spool carefully for burrs and scoring. Remove any burrs with crocus cloth.

**CAUTION:** *Do not round off the sharp edges on the valve spool or the operation of the valve may be affected.*

4. Inspect the control valve housing for burrs and scored or damaged surfaces. Remove any burrs with crocus cloth.
5. Insert the valve into the housing. The valve spool

should fall freely of its own weight into the housing (the specified valve spool to control valve housing clearance is 0.0002-0.0005 inch).

6. If it has been determined that the check valve assembly should be replaced, proceed as follows:
  - a. Install a new check valve assembly in the valve housing.
  - b. Install a new "O" ring on the plug and install plug.
7. Inspect the mating surfaces of the ball stud retainer and the sleeve assembly for wear or damage. The surfaces should be free of burrs and scores. Minor burrs and scores may be removed with crocus cloth.
8. Check the fit of the ball stud retainer in the sleeve assembly. The retainer should slide freely in the sleeve.

#### D. Control Valve Assembly

The control valve is shown disassembled in Figure 13. The valve is assembled as follows:

1. Lubricate the control valve assembly parts with Automatic Transmission Fluid—Type A, prior to installation. Check each part, as it is installed, for dirt or foreign matter which might impair the operation of the system.
2. Position the ball stud seat at the closed end of the ball stud retainer, then position the retainer in the sleeve and flange assembly. See Figure 13.
3. Insert the ball stud in the sleeve through the open end of the tube and place the threaded portion through the elongated slot in the sleeve and flange assembly.
4. Place the ball stud seat and spring in the ball stud retainer, then position the stop plug with the head of the plug toward the open end of the retainer.

**CAUTION:** *Be sure that the ball stud seats are properly aligned in the retainer.*

5. Position the valve spool bolt in the stop screw, then position the stop screw in the ball stud retainer. Move this retainer toward the open end of the sleeve and flange assembly. Tighten the stop screw securely, then back it off until the nearest hole in the stop screw is aligned with the hole in the valve spool bolt head.
6. Install the stop pin through the stop screw and through the slot in valve spool bolt head.
7. Install the dust shield on the sleeve and flange assembly.
8. Cover the control valve spool with a light film of Automatic Transmission Fluid—Type A, then insert the *large end* of the control valve spool into the front, or cylinder end of the control valve housing.

9. Lubricate the small control valve spool seal, then carefully install the seal in the valve housing (around the small end of the valve spool) with the cup side in.

**CAUTION:** *Do not nick or scratch the control valve spool seals during installation or fluid leakage may occur when the power steering system is placed in operation.*

10. Position the valve spool seal retainer (with the small I.D.) on the small end of the valve spool and against the spool seal.
11. Lubricate the large control valve spool seal and carefully install the seal in the valve housing against the large end of the valve spool. Place the seal retainer (with the large I.D.) on the large end of the valve spool in the same manner as directed for the small end.
12. Check the valve spool for freedom of movement in the housing.
13. Position the control valve stop plate in the control valve housing assembly at the small end of the valve spool.
14. Position the spool spacer on the valve spool bolt and against the stop screw.
15. Insert the top mounting bolt into the sleeve and flange assembly prior to positioning the assembly to the valve housing.

**NOTE:** *This procedure will provide the necessary bolt clearance between the top flange hole of the sleeve assembly and the steering ball stud.*

16. Position the sleeve and flange assembly on the valve housing by inserting the valve spool bolt completely through the bore of the assembled control valve spool, component seals and seal retainers. Make certain that the counterbore in the sleeve and flange assembly locates on the pilot of the valve housing, then insert the top mounting bolt through the top bolt hole in the valve housing to align the steering ball stud with the pressure and return ports of the valve housing.
17. Install the retaining lock nut on the cylinder end of the valve spool bolt. Tighten the nut to seat parts solidly and then back off the nut sufficiently to allow the valve spool to rotate freely in the valve housing with a minimum amount of end play.

**CAUTION:** *If the retaining lock nut is too tight, it may cause the valve spool to cock on the valve spool bolt. This will cause a binding condition of the valve spool within the spool bore of the control valve housing.*

18. Install the remaining two bolts through the sleeve and flange assembly.

### E. Power Cylinder Disassembly, Inspection and Repair

The construction of the power cylinder assembly does not permit repair of the piston or piston rod. If internal failure occurs, the power cylinder assembly must be replaced as a complete unit. However, seals can be replaced if they become worn or damaged.

1. Clean all dirt from the outside of the power cylinder assembly.
2. Clamp the power cylinder in a vise.
3. Remove the snap ring from the piston rod end of the power cylinder and pull the piston rod outward to remove the dust seal and washer scraper from the cylinder.
4. Apply compressed air to the port in valve housing end of the cylinder and blow the bushing and oil seal out the end of the cylinder. If this procedure does not work, use a sharp pointed instrument and pry the oil seal out. Replacement of the seal will then be necessary.
5. Examine the seals for wear or damage and replace them if necessary.
6. Lubricate the oil seal, then install the seal (cup toward piston), the bushing, dust seal, and washer scraper in the power cylinder with a  $1\frac{1}{16}$ " deep wall socket.
7. Install the snap ring in the end of the power cylinder.

### F. Power Cylinder Assembly and Installation

The assembly sequence for the power cylinder is shown in Figure 13.

1. Attach the power cylinder to the valve housing assembly using new "O" rings at the oil transfer ports.
2. Line up the oil transfer ports in the power cylinder with the ports in the valve assembly and tighten the three retaining bolts to 35 to 50 ft. lbs. torque.
3. Inspect all the washers and rubber bushings for wear or damage and replace them wherever necessary.
4. Install the cylinder and valve assembly as follows:
  - a. Jack the tractor sufficiently high to free the front wheels and align the front steering arm vertically as shown in Figure 14.
  - b. Install the cylinder and valve assembly by insert-

ing the front ball stud of the assembly into the front steering arm of the tractor. Secure with steering arm bolt and lockwasher.

- c. Install the inner insulator washer on the piston rod so that it bears against the shoulder on the rod. Install the inner rubber insulator so that it bears against the inner insulator washer.

- d. Position the cylinder rod through the hole provided in the cylinder support bracket and install the outer rubber insulator and insulator washer to the end of the rod.

**NOTE:** *The outer insulator washer has an I.D. of .464-.474 and the inner insulator washer has an I.D. of .515-.525.*

- e. Secure the rod by tightening the nut until the inner insulator washer is fully bottomed, then torque the nut to 20-25 ft. lbs. Lock the nut in place with the hex stamped nut.

5. Adjust the distance from the center of the cylinder steering ball stud, to the center of the front ball stud by loosening the clamp at the outer sleeve end of the cylinder assembly and rotating the cylinder assembly. The distance between these centers should be  $5\frac{1}{8}$  inches as shown in Figure 14. The face of the valve housing (containing the oil ports) should be on a horizontal plane when this measurement is made and the clamp tightened.

6. Install the return hose (connected at one end to the pump reservoir) to the rear port of the control valve assembly (see Figure 14) and tighten with a hose clamp.

7. Install the pressure hose to the front port of the control valve assembly and tighten the connector.

8. Turn the tractor steering wheel to align the front drag link hole with the control ball stud of the cylinder and valve assembly and install drag link to the control ball stud, using castellated nut and cotter pin.

**CAUTION:** *Do not cock the steering ball stud to make the necessary alignment with the front drag link hole. The steering ball stud must remain in a vertical position.*

9. Adjust the assembled drag link length to  $44\frac{5}{8}$ " between centers of the steering ball stud and rear ball stud as shown in Figure 15.

**NOTE:** *This adjustment is made by loosening the drag link sleeve clamps and turning the screw type drag link sleeve in the desired direction. Tighten the clamps after adjustment has been made.*

10. Replenish the system with hydraulic fluid in accordance with instructions given in item 5, under E-Installation on page 13.



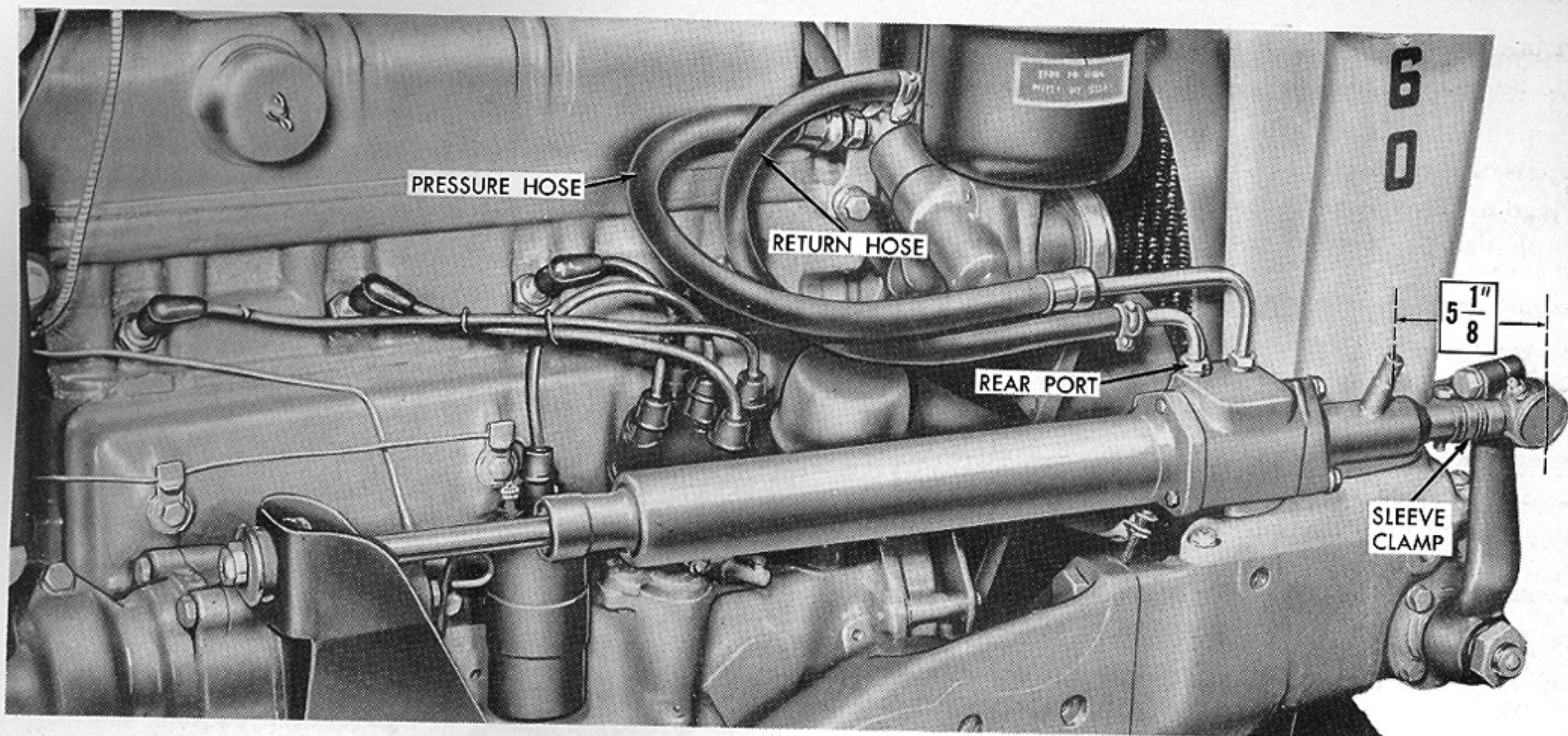

Figure 14—Cylinder and Valve Assembly Adjustment

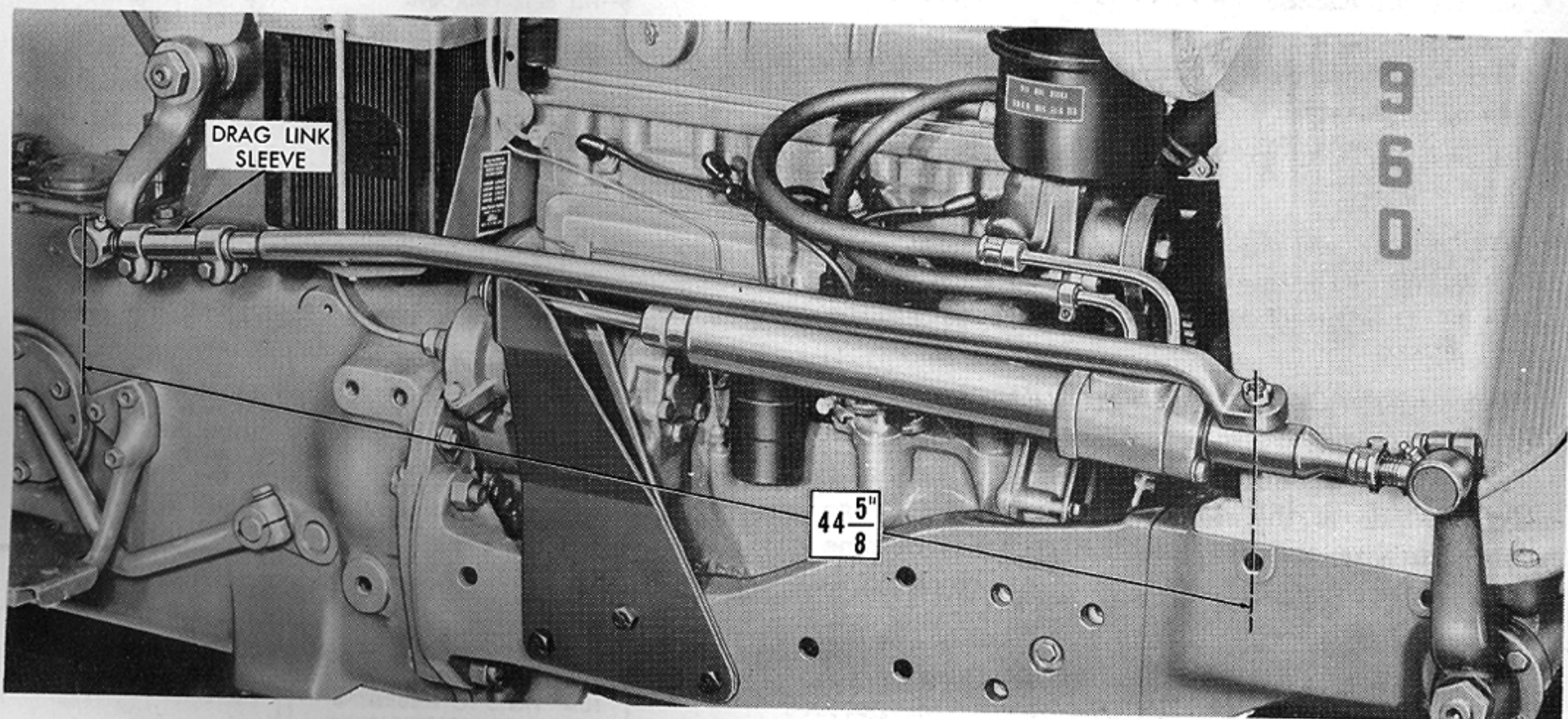

Figure 15—Drag Link Adjustment

#### 4. MAINTENANCE

Very little maintenance is required to keep the power steering system operating properly. The oil reservoir should be filled to within  $\frac{1}{2}$ " of the top with Automatic Transmission Fluid—Type A, after installation on the tractor, and the level should be maintained thereafter.

The oil should be changed only when it is necessary to drain the power steering system for repairs.

The oil filter element assembly should be replaced if

damaged or considerable sediment is noted, using the following procedure:

1. Remove the oil reservoir cover and gasket and withdraw as much oil as possible from the reservoir with a suction gun.
2. Lift the filter element retaining spring, hook, spring seat and filter element from the reservoir. Clean the reservoir thoroughly.

3. Position a new filter element on the support plate, lay the filter element retaining spring seat on the element, then install the retaining spring in position on the spring seat.
4. Place a new reservoir cover gasket in the cover.
5. Replenish the system with Automatic Transmission

## 5. TROUBLE SHOOTING

The power steering system has been designed to provide many hours of trouble free operation. But, like any mechanical device or system, the units of the power steering system may become worn or out of adjustment. As a result, the normal, smooth operation of the system may be affected. The information given below is designed to help the service man quickly locate and correct most of the difficulties that may be encountered.

### A. Loss of Power Assist

A road map outlining the procedure for checking and correcting the difficulty, "Loss of Power Assist" is shown in Figure 16. After you familiarize yourself with the procedure, a glance at the road map will be all that is needed to trouble shoot the symptom.

### B. Binding

If a binding or sticking condition is noticed when the steering wheel is turned, check the following items in the order given:

(1) **STEERING-BALL STUD MOVEMENT:** There may be an interference at the sleeve, dust shield and steering ball stud connection. If the ball stud is rubbing against the side of the slot in the sleeve and flange assembly, to a point where the ball stud has become grooved, replace the ball stud. If the dust shield is cramped into the sleeve assembly, replace the dust shield.

(2) **CONTROL VALVE SPOOL:** Check the operation of the control valve spool in the housing. If the valve spool is binding in the housing and the control valve stop screw adjustment is correct, replace the control valve spool and housing.

### C. Excessive Free Play in Steering

If excessive free play or lost motion is noticed when steering, check the following items:

(1) **STEERING-ARM BALL STUD SEATS.** Check for excessive clearance between the steering arm ball stud and the ball stud seats. If the ball stud is loose in the seats, check the ball stud spring tension. If the spring is faulty, replace the spring.

Fluid—Type A in accordance with instructions given in item 5, under E-Installation, page 13.

**NOTE:** The power steering system has only one grease fitting which is located in the control valve sleeve. Lubricate this fitting every 10 hours with pressure gun grease.

(2) **CONTROL VALVE STOP SCREW.** Check the adjustment of the control valve stop screw and adjust as specified. Make certain that the roll pin is installed in the stop screw at this adjustment.

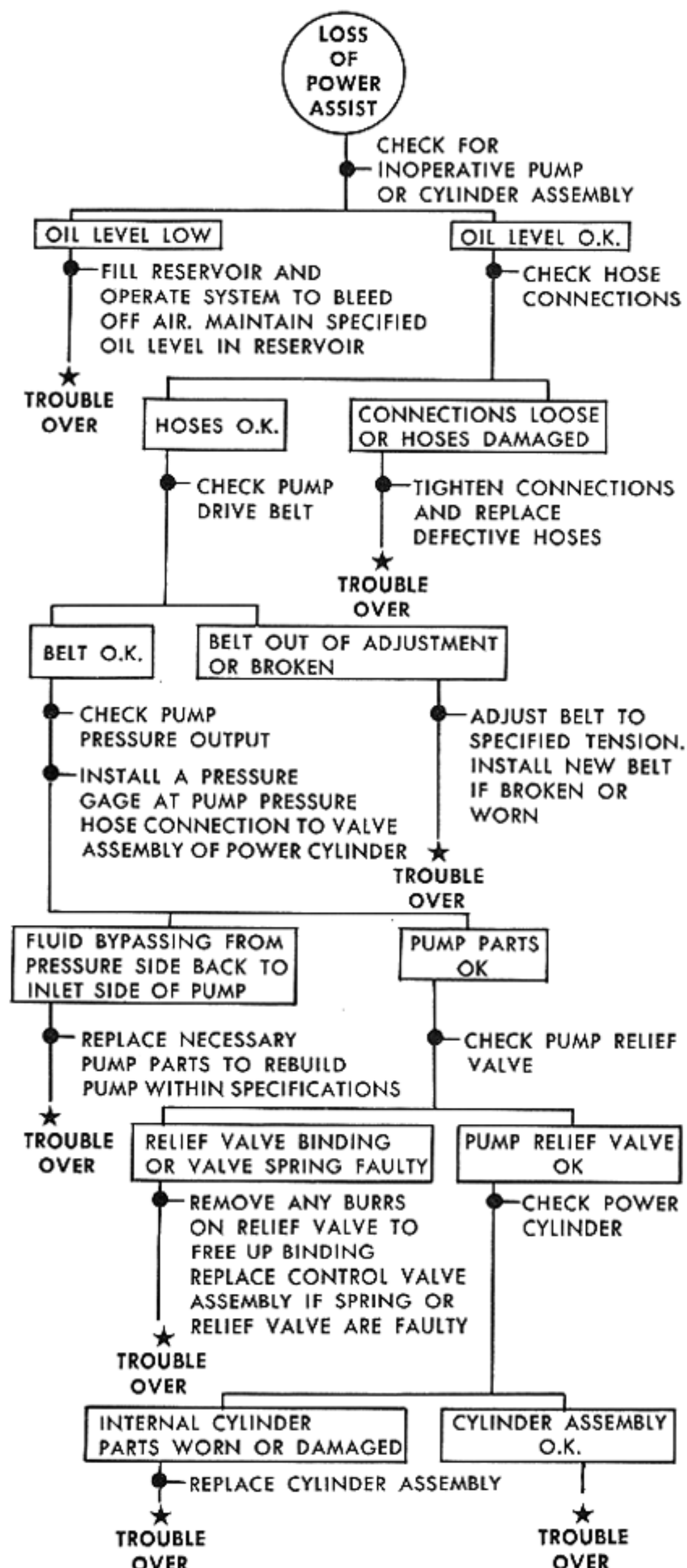

Figure 16—Loss of Power Assist—Road Map

